



# Series T – 나사식 볼밸브 (Threaded Ball Valve)



형식	Series T – Threaded
사이즈	• Series T - 8mm ~ 50mm
압력 범위	• 8mm ~ 50mm – 138bar / 207bar / 414bar
바디 (Body)	• Carbon Steel ASTM A216 WCB • Stainless Steel ASTM A351 CF8M
볼 (Ball)	• Stainless Steel ASTM A351 SS 316
스텝 (Stem)	• Stainless Steel ASTM A479 SS 316
시트 (Seat)	• RPTFE / PEEK
누수 등급	Class VI
설계 기준	API 608, ASME B16.34
검사 기준	API 598

## DeVal Series T

Engineering

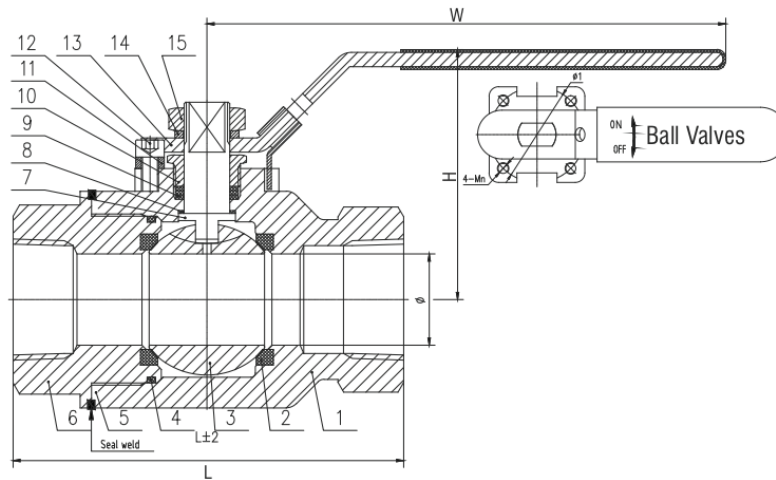

DIMENSIONS (mm)

Sizes	2000 Psi			3000 Psi			6000 Psi		
	L	W	H	L	W	H	L	W	H
1/4	60	55	100	98	60	147	111	60	147
1/2	75	60	120	98	60	147	111	60	147
3/4	81	60	155	108	71	192	111	60	152
1	91	75	155	137	88	185	137	91	256
1 ¼	110	80	155	137	94	228	137	95	256
1 ½	120	95	185	160	115	268	160	130	370
2	140	110	185	160	138	300	160	130	370