

# Series 64 – 3-PC 산업공정용 볼밸브 (Three-Piece Industrial Process Ball Valves)



형식	Series 64 – Threaded NPT(ASME B 1.20.1) / BSPT(BS 21), Socket Weld, Butt Weld
사이즈	• 15mm ~ 50mm
압력 범위	• 15mm ~ 50mm – ASME Class 400 (69bar)
바디 (Body)	• Carbon Steel ASTM A216 WCB • Stainless Steel ASTM A351 CF8M
볼 (Ball)	• Stainless Steel ASTM A351 CF8 / CF8M
스텝 (Stem)	• Stainless Steel ASTM A479 SS 304 / 316
시트 (Seat)	• PTFE / RTFE
누수 등급	Class VI
설계 기준	BS EN 17292
검사 기준	API 598



DelVal® Series 64

## Engineering

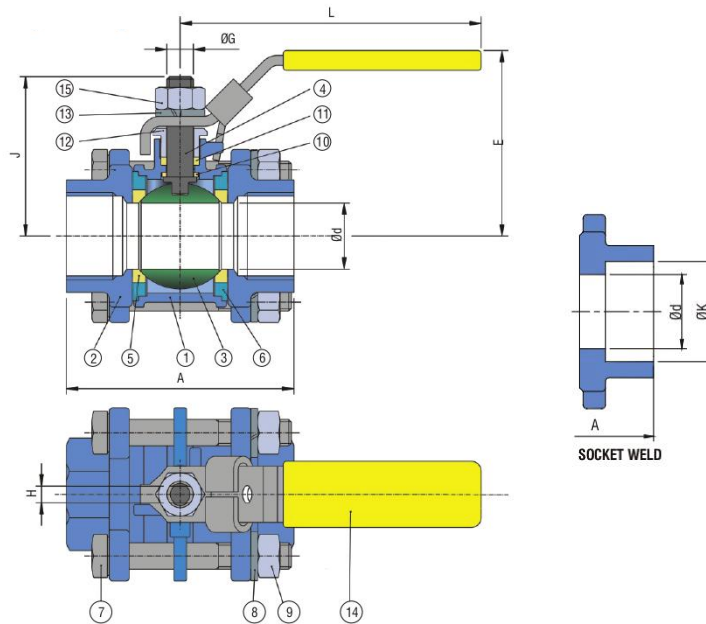

## DIMENSIONS (mm)

Size	DN 15 / 1/2"			DN 20 / 3/4"			DN 25 / 1"		DN 32 / 1-1/4"		DN 40 / 1-1/2"		DN 50 / 2"	
	FB	FB	RB	FB	RB	FB	RB	FB	RB	FB	RB	FB	RB	
A	63.5	68	68	79	79	90	90	107.5	107.5	129	129			
ØG	8	8	8	10	8	10	10	14	10	14	14			
H	5	5	5	6	5	6	6	10	6	10	10			
J	42.5	48	42.5	57.5	48	63	57.5	74	63	88	74			
Ød	15	20	15	25	20	32	25	38	32	50	38			
ØK	21.7	27	27	33.8	33.8	42.5	42.5	48.6	48.6	61.1	61.1			
L	101	101	101	144	101	144	144	198	144	198	198			
E	53.5	56	53.5	74.5	56	80	74.5	93.5	80	102.5	93.5			
Weight (Kg)	0.53	0.79	0.70	1.42	1.3	3.4	2.3	4.5	3.2	7.5	6			
Torque (Nm)	7	10	7	15	10	26	15	34	26	45	34			